

型號 / type

孔徑 / inside dia



圓盤型高剛性聯軸器

CM-HT 尺寸表 / Dimension

單位 / Unit : mm

規格 NO	D1×D2/公差 Tolerance(H8)		H	K	B	E	T	L	M1	M2
	min	max								
HT40	8	16	38	40	16	3.95	2.8	35.95	M4	M4
HT56	10	16	48	56	20	4.9	3.5	44.9	M5	M5
	18	25	54							
HT68	14	22	54	68	25	4.25	4	54.25	M6	M6
	24	30	64							
HT82	16	22	56	82	30	4.75	4	64.75	M6	M6
	24	30	64							
	32	35	69							
HT94	19	22	58	94	30	9.4	4	69.4	M6	M8
	24	30	68							
	32	40	78							
	42	48	88							
HT105	24	30	68	105	30	10	4	70	M6	M8
	32	40	78							
	42	50	88							
	55	60	98							

CM-HT 特性表 / Specifications

規格 NO	常用 扭力 (N.m)	容許角度偏差 Allowable Angular Error			最高 轉速 (rpm)	彈簧 定數 (N.m/rad)	軸向 彈簧 定數 (N/mm)	慣性矩 (kg.m ²)	重量 (g)
		偏心 (mm)	偏角 (o)	軸向 位移 (mm)					
HT40	7	0.02	1	±0.25	6000	10000	50	2.8×10^{-5}	120
HT56	25	0.02	1	±0.40	6000	16000	43	12×10^{-5}	308
HT68	60	0.02	1	±0.45	6000	60000	45	28×10^{-5}	560
HT82	90	0.02	1	±0.45	6000	70000	60	35×10^{-5}	855
HT94	180	0.02	1	±0.80	6000	140000	120	108×10^{-5}	1500
HT105	250	0.02	1	±0.80	6000	160000	160	115×10^{-5}	1700

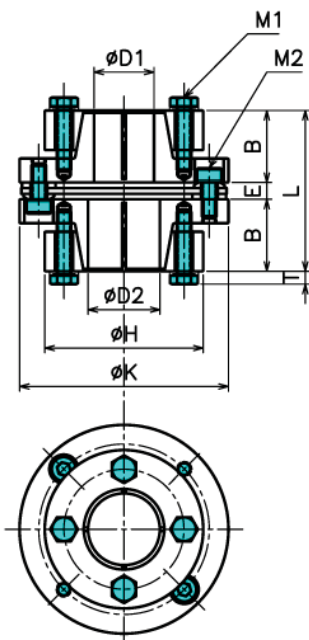

FEATURES :

- ✦ 低慣性零迴轉間隙 / Low Inertia , Zero Backlash
- ✦ 具緩衝抗震功能 / Flexibility and Vibration Resistance
- ✦ 錐型固定方式安全可靠 / Secured by Conical Clamping
- ✦ 適用伺服馬達或精密定位傳動 / Applicable for Servo Motor or Precise Positionin Transmission
- ✦ 免保養壽命長 / Maintenance-free ; Lfinite Life
- ✦ 本體鋁合金材質輕量化 / Aluminum Alloy Body : Light-weight